







*Service Excellence*  
built on  
*Firm Foundations*

Founded in 1990 in West London by George Higgins and David Higgins, G&D Higgins Ltd. has grown rapidly to become one of the industry's best known and most respected providers of quality project and maintenance services.

With a strong background in the mechanical services industry, G&D Higgins understands the industry's need for flexibility and expertise.

Continuing investment in staff training and development has enabled the company to readily satisfy customer needs, creating a multi-million pound mechanical services operation. And as its portfolio of clients has expanded, G&D Higgins' long-standing customers continue to return to a guaranteed high level of service.



# A Complete Service for all Mechanical Projects

G&D Higgins is committed to investing in the resources needed to meet varying customer requirements. We employ skilled full-time staff to provide in-house design capability,

professional project management, expert pipe work and highly efficient installation – ensuring easy access to the mechanical services required for any project.

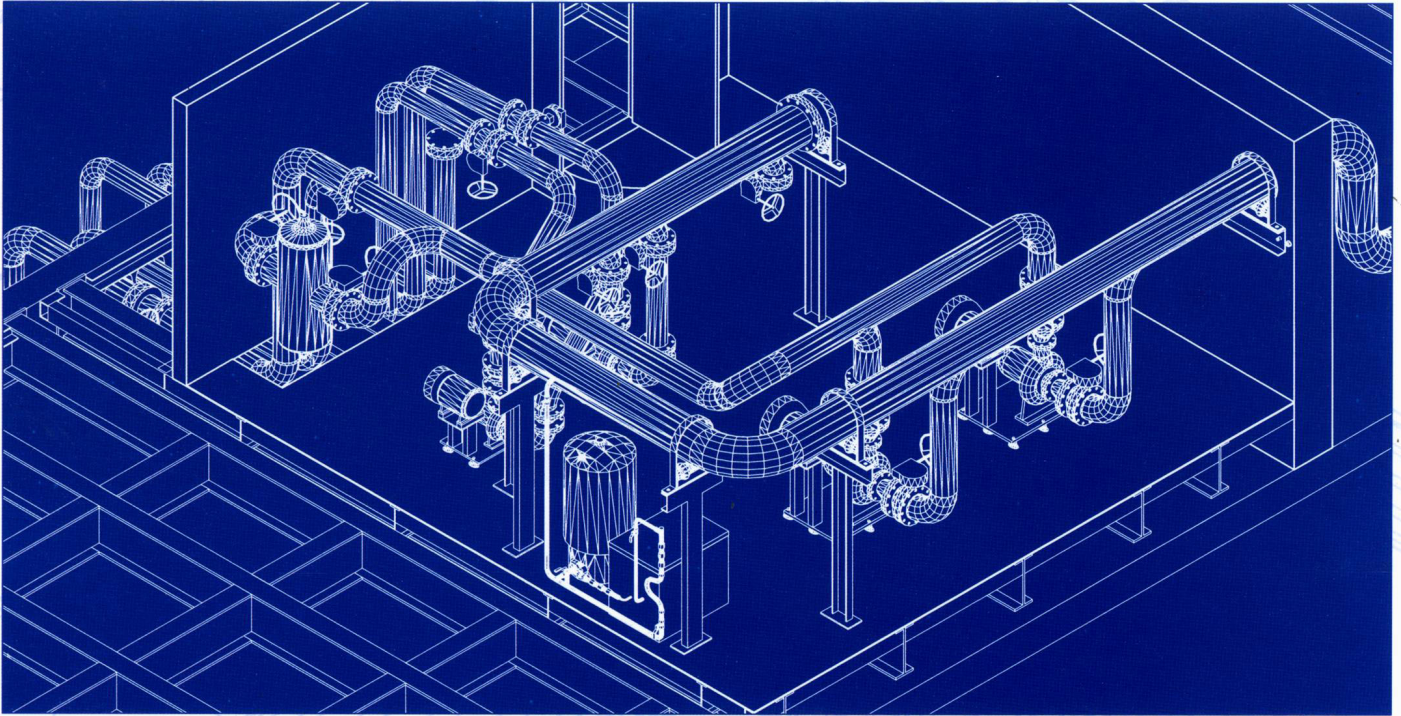

## Key Skills from one Reliable Source

### *In-house CAD Design*

Our in-house design department offers a fully qualified CAD capability. From green field sites through to refurbishments, we can design your installation, then specify and install the plant required.

### *Top-class Welding Capability*

Calling on our team of welders, we offer high levels of expertise for all types of mechanical applications, including a full range of pipe work services.

### *Installations*

G&D Higgins specialises in the installation of control systems, air conditioning, chillers, ventilation systems and gas-fired boilers.

### *Plant Replacement & Refurbishment*

From cold water storage tanks through to large industrial boilers, we can deliver new installations or replace or upgrade your existing plant.

### *Plumbing & Drainage*

These expert services are available for any new contract or as part of an on-going maintenance agreement.

### *Project Management*

From the start we work with you to ensure that the most efficient and cost-effective solution is deployed. We can also provide a troubleshooting and testing service.

### *Maintenance*

Maintenance agreements are available for new and existing customers offering a complete range of options - from 24-hour callout services through to scheduled maintenance visits.



# Customer Case Studies

## *Royal Garden Hotel, Kensington*

Following a stringent selection procedure, G&D Higgins was asked to replace three steam boilers with Low Temperature Hoval Boilers. As hot water is essential to the hotel's operations, the changeover was progressive to ensure uninterrupted services.

In total, over twenty skilled staff provided CAD design capability, handled the pipe welding and fabrication, refurbished the boiler room and completely overhauled the hotel's air handling system on ten floors.



*"Since G&D Higgins has a proven experience in this field, we were able to visit three reference sites to see similar projects. This gave us every confidence in their capabilities."*

David Abercrombie, *Chief Engineer, Royal Garden Hotel*

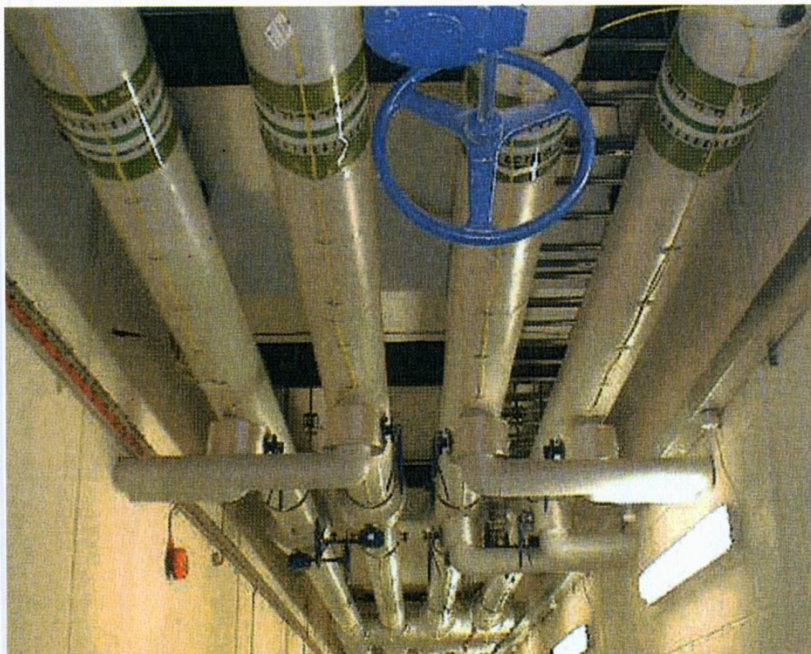

*"Not many companies can provide the level of technical expertise we require while offering truly competitive tenders."*

Martin Kelly, *Senior Technical Engineer, Cable & Wireless*

## *Cable & Wireless*

For five years G&D Higgins has been an approved supplier for the telecommunications giant, winning competitive tenders worth several million pounds for both office air conditioning and refurbishment, as well as specialist switching room air handling systems.

G&D Higgins installed under-floor cooling systems in the switching rooms at two major Cable & Wireless sites, providing up to four Megawatts of cooling capacity. Welding staff assigned to the projects were Class 1 6G qualified, and all pipe work was subject to the highest standard of non-destructive X-ray testing.



# Customer Case Studies

## *Brunswick Centre, Camden*

Working alongside leading consultancy, NIFES, G&D Higgins undertook the complete installation of a new four Megawatt boiler house, valued at £760,000. The project was designed to provide heating for the Brunswick shopping centre and associated residential buildings.

G&D Higgins co-ordinated all aspects of this time-critical installation, which included a BMS control system, six Hoval boilers and Hoval pressurisation and connections to the main pipe work.

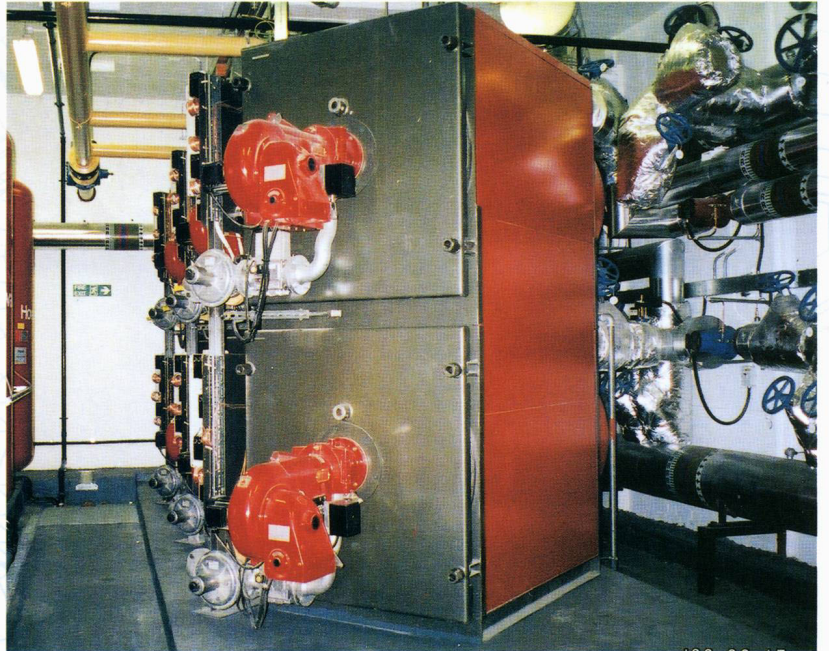

*“G&D Higgins met our extremely tight timescales, carrying out the installation to the very highest standards. They made a complex project look simple.”*

Harry Yates, *Senior Engineer, Camden Council*



*“We enjoy working with G&D Higgins because we know we can rely on them to get the job done. They take personal responsibility at board level, regardless of the size of the project.”*

David Leech, *London Borough of Harrow*

## *London Borough Councils*

G&D Higgins provides maintenance and contract services to many London Borough Councils, including Harrow, Hillingdon, Kensington and Chelsea, Ealing and Camden.

The company began working for the London Borough of Harrow in the early 1990's, and its maintenance contract has since been renewed on a regular basis. Engineers respond to callouts for schools, colleges or community housing within an agreed timescale and G&D Higgins also undertakes a variety of heating, hot water and gas boiler replacement projects.





## *Success* based on *Customer Care*

G&D Higgins is experienced in providing tailor-made solutions for each specific project - whether for Local Government and Education, specialist telecommunications or laboratory environments, industrial applications, hotels or other commercial developments.

From multi-million projects through to smaller one-off projects for local contractors, we provide an efficient and cost-effective solution whatever your needs. Whether we're installing a £2,000,000 chilled water-cooling system at Canary Wharf or refurbishing a small flat, we aim to provide consistently high standards of service across the board.

Acting as a prime-contractor or as an integral member of a wider project team, we assign skilled personnel - professionally qualified mechanical engineers, CAD designers and Class 1 6G welding staff - to complete your project on time and on budget.

For larger projects, we can also assign on-site technical project managers to manage all aspects of your installation. And in every instance, your project will be personally overseen by one of G&D Higgins' Directors, underlining our commitment to quality control and customer care.



# At Your Service

Founding directors George Higgins and David Higgins share a common belief in the importance of investing in management and skills expertise in order to meet the evolving demands of the industry.

G&D Higgins has also made significant investments in infrastructure with new premises, the latest computer technology and an extensive fleet of vehicles. The

company's commitment to employing, training and retraining staff in their specialist fields maintains a consistently high quality of service for customers.

This investment not only demonstrates G&D Higgins' successful business growth, it ensures that the company continues to meet and exceed customer expectations.

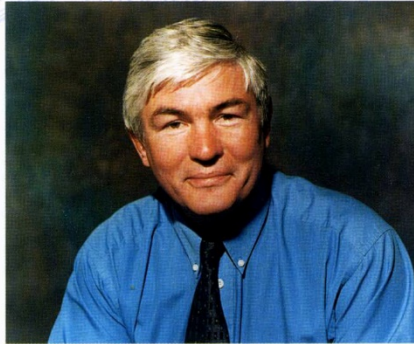

David Higgins *Managing Director*

Since the 1980's David Higgins has built up a wealth of experience working with large corporations such as Cable & Wireless, through to small consultancies and contractors.

*"To provide the highest levels of service, we consider it vital to keep up-to-date with the latest industry trends and skills. We are proud of the fact that G&D Higgins has received an HVCA certificate in recognition of our advanced staff training programmes."*



*Building Skills for the Industry*

*Accredited by the Industry*

The G&D Higgins organisation is registered with Corgi, HVCA and Construction Line

G&D Higgins runs an extensive training programme for staff. Welders are qualified to Class 1 6G and Class 2 levels. The company's in-house design team is qualified to Degree/HND level in Mechanical Engineering and City&Guilds level in AutoCAD design.







*Mechanical services from  
a professional, dedicated team*



**Mechanical  
Services Ltd**

*For more Information*

For more information about G&D Higgins  
or an informal discussion about a project,  
please call David Higgins or email  
[enquiries@gdhiggins.co.uk](mailto:enquiries@gdhiggins.co.uk)

*Telephone: 020 8863 0003*

*Facsimile: 020 8863 0029*

*[www.gdhiggins.co.uk](http://www.gdhiggins.co.uk)*